

How to order a Rodriguez Bicycle

If you live in our area and can make it to Seattle call us at 206-527-4822 to set an appointment, or send us an e-mail at info@rodbikes.com

 www.rodbikes.com

Steps for purchasing a Rodriguez from outside the State of Washington:

- More detailed information is available in the FAQ section of our web site
- First a bicycle fitting is performed on the rider (see Fit Instructions next page)
- The fitting information is then sent, e-mailed, faxed, or called in to us along with bike interests (see below)
- After fit information is received, we can recommend a size of frame for the best fit
- Fill out the 'Which bike are you interested in?' form and send it in with your fit measurements (At this stage we usually will exchange several e-mails, phone calls etc... because we really like to give personalized service)
- After we've decided on fit and the model that works, a 50% deposit is paid and we start the bike
- Shipping and handling charges are as follows (insurance included):

Inside the Continental U.S.

\$250 shipping and handling to your doorstep for a regular bike (\$125 for a frame/fork only).

\$450 shipping and handling for a standard tandem (\$250 for a frame/fork only).

\$175 shipping and handling for a S&S coupled travel single bike (\$125 for a travel frame/fork only).

\$300 shipping and handling for a S&S coupled travel tandem (\$150 for a travel tandem frame/fork only).

See our FAQ page, or shoot us an e-mail if you have any questions regarding a long distance order. We sell about 1/3 of our bikes to out-of-state customers, and each customer is different. We can address any individual concerns that you may have about ordering a bicycle that you haven't seen yet.

Custom Bicycles and Tandems:

You'd like a bike, but you don't see a model that you want in our catalog? In the event that you would like to order a completely custom bicycle, we do a lot of that also. Simply fill out the fit form(s) for the rider(s) and just let us know what type of custom bike you're interested in. We've been a custom builder since 1973, so chances are that we have already built something like the bike of your dreams. It can then be faxed to us at 206-527-8931 or sent to us at R+E Cycles • 5627 University Way NE • Seattle, WA 98105

Custom Paint:

We keep about 40 colors in stock and can custom order any color that you'd like. After we've had a chance to discuss your preferences, we will work with you on color and paint design 'one on one'.

Rodriguez Bicycle Fitting Instructions.

Follow the instructions below and fill in the measurements on page 4.

FITTING INSTRUCTIONS

If you own a metric tape measure you can take the measurements in metric. If not, don't worry about it, we will convert the numbers for you.

To perform the fit you will need a partner, a tape measure, and a rigid ruler or carpenter's square. The measuring needs to be done in bare feet or light socks while holding your body erect.

1.) INSEAM: While standing with your feet about 2 inches apart pull the ruler firmly up into your crotch, keeping one hand in front and one in back. Have your partner make sure the ruler is level and record the distance from the top of the ruler to the ground in inches (or centimeters if you have a metric tape). If using a carpenter's square do all measuring against a wall to maintain level on the square.

2.) THIGH: While kneeling with your knees about 5 cm apart, follow the same procedure as for the inseam measurement.

3.) FOOT LENGTH: Position your heels against the wall and measure the distance in centimeters from the wall to the end of the large toe.

4.) TORSO: This is the reverse inseam measurement. Hold the ruler level against your crotch and have your partner measure the distance from the ruler to the top of your manubrium (This is the "V" shaped soft area below your Adam's apple. The measurement will be to the bottom of "V".) This is easy to do if your partner hooks the tape on the bottom edge of the ruler and subtract the width of the ruler before the measurement is recorded.

5.) ARM: With the ruler held the way an archer would grip a bow, hold your arm at about a 45 degree angle extended out to the side. Your partner will measure from the ruler to the edge of your shoulder.

6.) SHOULDER WIDTH: Measure the distance from the edge of each shoulder from acromion* to acromion*.

* The edge of your shoulder is marked by the acromion. To find the acromion, let your arm hang down at your side. With the other hand, feel down the side of your neck and along the top of your shoulder. Just about where the top of your shoulder ends and your arm begins, you will feel a bony point. This is your acromion. Check to make sure that you have found the right spot by continuing to feel the point with your finger while you move your arm around. You will feel that this is the point where the movement of your arm originates. Remember to subtract the width of the ruler before recording the measurement.

7.) YOUR HEIGHT

8.) YOUR WEIGHT

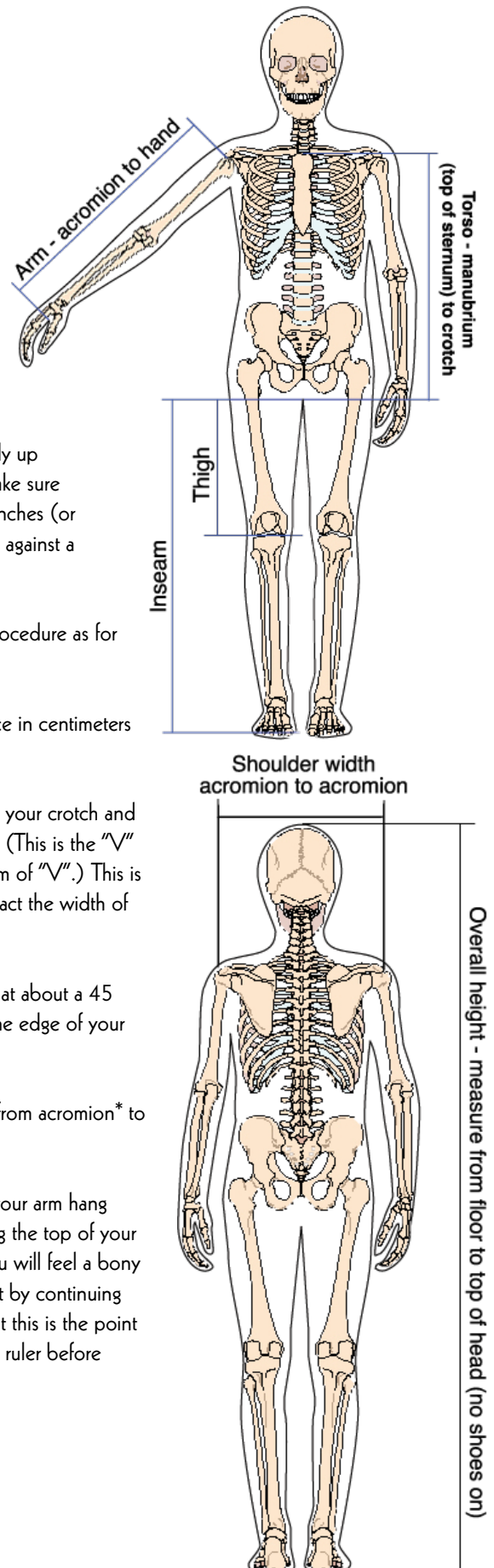

EXISTING BIKE NUMBERS:

If you are currently riding a bike that you like, or dislike, it will be helpful if we know the current fit measurements that you are used to. If you really like, or dislike, your current bike we will be discussing all of that via e-mail or phone before we set up your new bike.

- 1.) **Seat tube** - along the angle of the seat tube measure from the center of the bolt that holds on the cranks to the top of the tube that the seat post is inserted into.
- 2.) **Seat height** - along the angle of the seat tube measure from the pedal in it's lowest position to the top of the seat.
- 3.) **Reach to bars** - measure from the center of the seat post where it attaches to the seat to the center of the handlebars. For this measurement hold the tape level to the ground.
- 4.) **Seat to ground** - measure from the top of the seat to the ground. Hold the tape measure perpendicular to the ground.
- 5.) **Bars to ground** - measure from the top of the bars to the ground. Hold the tape measure perpendicular to the ground.

DON'T WORRY:

Once the fitting numbers have arrived, that's just a beginning, so don't worry that we might build you the wrong size based on a mistaken measurement.

When you perform your own fitting numbers, expect that we'll have some questions for you once we've received the numbers. We've been fitting and building bicycles a long time, so we're used to looking over numbers and analyzing them. Very often, we will ask you to take one or more of the measurements again to clear up any discrepancies.

Some people have had a professional fitting done at a shop for their existing bike and they have the measurement print out. If this is something you have, feel free to send it along as a guide for us to compare.

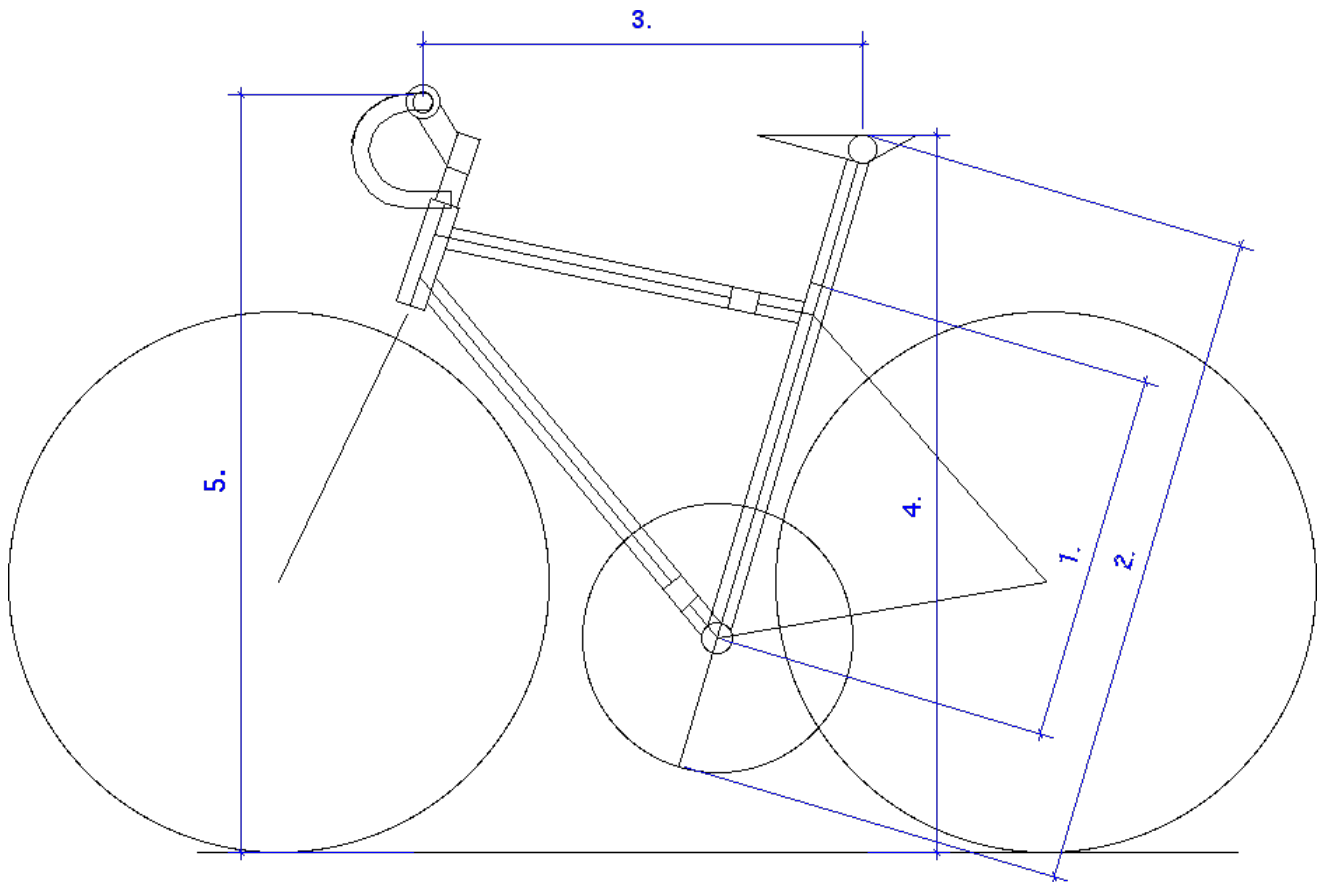

Rodriguez Bicycle Order Form

Date

Your Contact Information:

Name

Phone

E-mail

Address

City/St/Zip

Filling in this form is not a commitment.

1.) Complete this page and the next page to start the order process.

2.) You can mail, fax or e-mail the information to us.

3.) We will contact you via e-mail to firm up all of the details and clear up any questions that you (or we) may have.

FITTING NUMBERS:

1.) INSEAM:

2.) THIGH:

3.) FOOT:

4.) TORSO:

5.) ARM:

6.) SHOULDER:

7.) HEIGHT:

8.) WEIGHT:

CURRENT BIKE NUMBERS:

1.) Seat Tube

2.) Seat Height

3.) Reach to bars

4.) Seat to ground

5.) Bars to ground

What do you like or dislike about your existing bike?

Sizing is serious business at Rodriguez Bicycles.

If a bike doesn't fit right, it's not going to be ridden. A bike not ridden is a very sad bike. Our efforts here at Rodriguez Bicycles to prevent the creation of very sad bikes has been nonstop since the 1970's. At Rodriguez Bicycles, we've come up with our best solution ever!

Along with the development of the NEXT fit™ software system (see our web site for more info) came the realization that if we could fit 90 to 95% of our customers if we built our Rodriguez bicycles in 18 sizes instead of just 10. With the improvements in our frame shop, we no longer have to batch similar size and types of bicycle together when we manufacture them. This enables us to build 18 production sizes as easily as we could build 6 sizes (like most manufacturers).

For 2012 we will be offering 18 production sizes in addition to our custom offerings. The improvements don't end there, though. Our new manufacturing method smooths out things in our paint shop as well. This allows us to offer more choices in paint and decals at no extra charge. Any production bike can be painted one of 4 paint jobs, with your choice of 9 different decal styles (of course custom paint is still an option as always). See the web site for decal and paint options.

How about that? 18 sizes, 4 colors, 9 different decal options, and lighter weight, stronger tubing for every production bike we make, and no upgrade charges? Add to this the NEXT fit™ system of fitting, and you've got the best lineup we've ever offered!

Which bike are you interested in?

See the catalog for pricing, specifications, and upgrade options:

What type of long and short term goals do you have for this bike?

This form just gives us a basic idea of the bike and its uses. We will be contacting you with more questions and suggestions after receiving this form. This form does not complete an order, it just lets us know you're interested and would like to talk further.

Thanks, - Dan

